



Facet Part No: Filter Assembly 043721
Boeing Part No: Assembly 10-60555-1

Filter Assembly

Description of Operation

This filter assembly consists of a housing and seals suitable for Skydrol 500 fluid, a 10-micron stainless steel mesh cleanable filter element and a magnetic plug. Hydraulic fluid flows through the filter as shown by the arrows on the cutaway drawing. Foreign particles are removed by the filter element and are deposited on the outside of the element or in the filter bowl. The magnetic plug attracts magnetic particles and provides a visual means of inspection for metal chips which might indicate a failure of some components in the hydraulic system. The magnetic plug assembly includes an automatic shutoff valve to prevent drainage of fluid when the plug is removed.

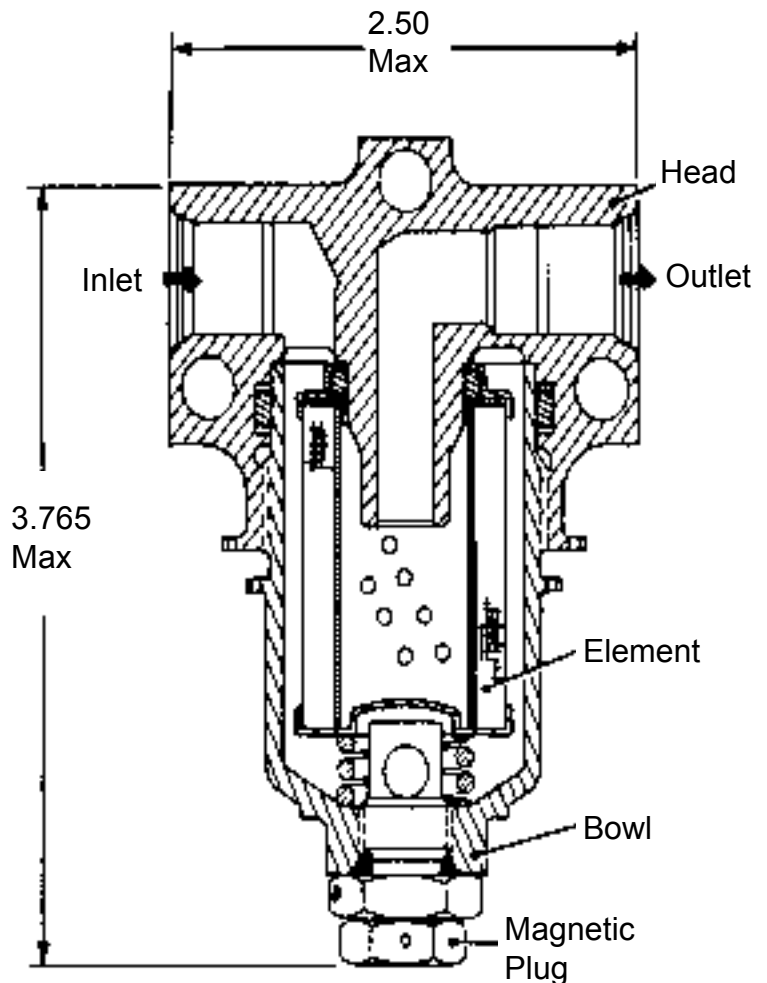

Facet Part No: Filter Assembly 043721

Boeing Part No: Assembly 10-60555-1

Filter Assembly

Parts List

Item No.	Part No.	Nomenclature	No. per Assembly	Item No.	Part No.	Nomenclature	No. per Assembly
1	See note	Magnetic Plug	1	8	049909	O-ring NAS 1611-114	1
2	049759	O-ring	1	9	910784	Backup Ring MS 28774-220	2
3	See note	Fitting	1	10	049411	O-ring NAS 1611-220	1
4	049948	O-ring NAS 1612-5	1	11	045994	Head	1
5	045993	Bowl	1		046001	Name Plate	1
6	045985	Spring	1		045988	Magnetic Plug Assembly	1
7	045991	Element	1				

Note: If Items 1 or 3 require replacement, use plug assembly 045988.

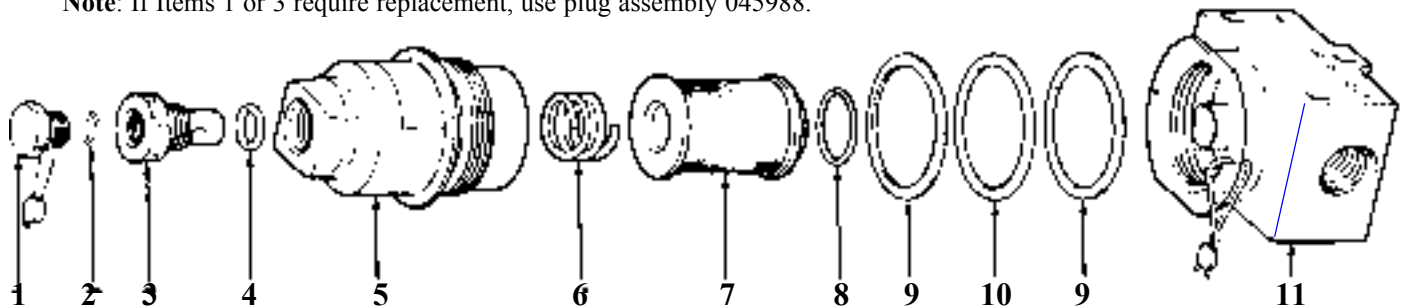

Maintenance and Overhaul Instructions

Disassembly: Disassembly of the filter follows the sequence of the assigned item numbers in exploded view.

Cleaning-External Aluminum Parts: Wash aluminum parts in a suitable solvent such as trichloroethylene, stoddard solvent, etc. Do not use strongly alkaline cleaners.

Cleaning-Element Assembly: Degrease and clean the stainless steel filter element in two separate steps.

Step 1: Remove the hydraulic oil and dirt cake by placing the filter element upright in a pan of solvent with the open end above the liquid level and soak for at least fifteen minutes. Agitate by hand but do not brush or wipe element surfaces. Rinse the outer surfaces with clean solvent. Do not allow dirty solvent to get inside the filter.

Step 2: Clean impacted dirt from the mesh by sonic cleaning, chemical cleaning or reverse flushing. Sonic cleaning is most effective when used with a water-detergent type cleaning solution. Chemical cleaning may be accomplished by boiling in a solution of 10 percent weight sodium hydroxide or proprietary cleaner followed by thorough water rinsing. Reverse flushing (flow from inside to outside) should be done in a series of abrupt bursts of flow ending with a blast of clean air.

Inspection: Head, bowl and drain plug should be examined for distorted threads or scoring.

Replacement Items: Replace O-rings. Replace element if damaged. Replace defective head, bowl or drain plug.

Lubrication: Before reassembly, lubricate O-rings and threads with Skydrol 500.

Reassembly: Reassemble in the reverse order of disassembly. Tighten lubricated head and bowl threads to 75 in. lbs.

Test: Observe for external leakage under test pressure of 600±25 psi.